

Regent pumps

A U S T R A L I A

founded 1948

FiFi Series

Fire Pump



Fire Pumps for

¼ FiFi

½ FiFi

FiFi I

FiFi II & III

..... all about moving fluids

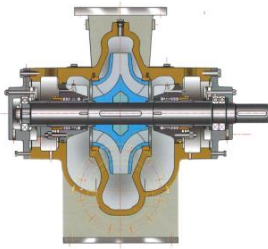

Horizontal Single stage Double Suction Split Case Pump

Standard Pump for FiFi I , II & III. Horizontal mounting with side-side, bottom-top and side-top suction/discharge execution.

Capacity : 1200 m³ to 4600m³
 Total Head : up to 250Metre
 Speed : Max 1800rpm

Materials:
 Pump Casing : Ni-Al-Bronze / GGG50
 Impeller : Ni-Al-Bronze
 Shaft : Stainless Steel

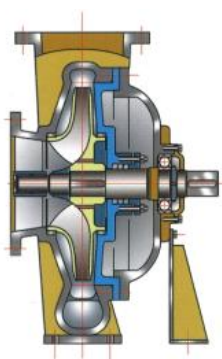
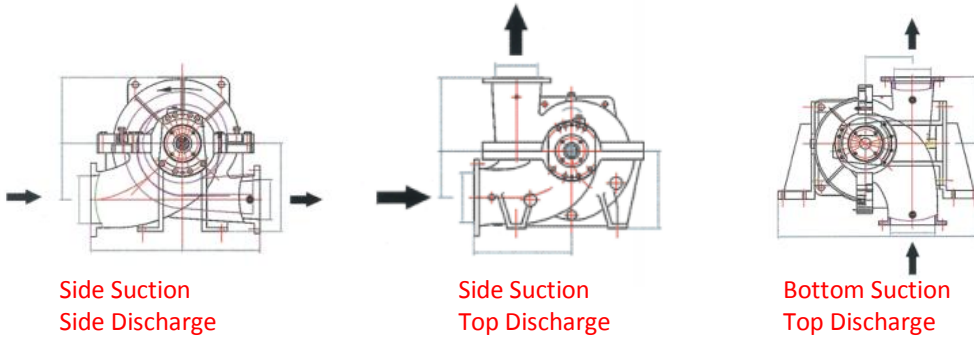

Horizontal Single Suction Radial split Centrifugal Pump

Standard Pump for FiFi I.
 Horizontal mounting End Suction

Capacity : 1200 m³ to 1600m³
 Total Head : 110 to 170Metre
 Speed : Max 1800rpm

Materials:
 Pump Casing : Ni-Al-Bronze / GGG50
 Impeller : Ni-Al-Bronze
 Shaft : Stainless Steel

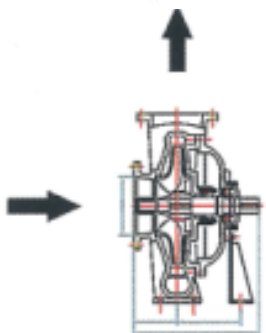
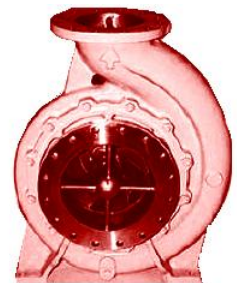

Horizontal End Suction Centrifugal Pump

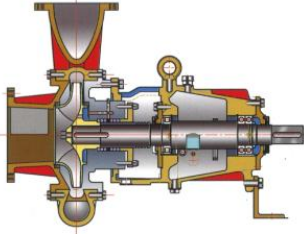

Standard Pump for FiFi ¼, ½
Horizontal mounting End Suction

Capacity : 200 m³ to 900m³
Total Head : 110 to 320Metre
Speed : Max 3000rpm

Materials:
Pump Casing : Ni-Al-Bronze / GGG50
Impeller : Ni-Al-Bronze
Shaft : Stainless Steel

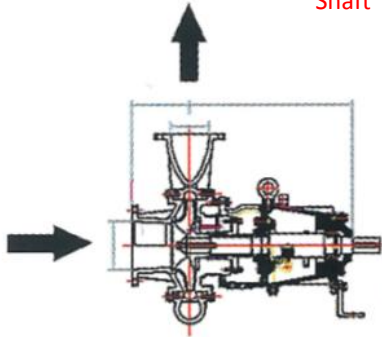

Side Suction
Top Discharge

Pump Packages



Other Regent Pumps Range

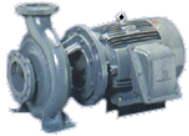

Dinbloc /ISObloc
Direct Coupled



Dinflow/ISOflow – Bare Shaft



Linebloc- DIN/ISO

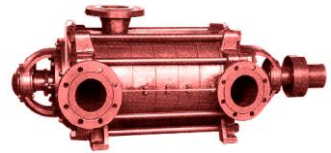

RPTS-Single or Multiple outlets –
Horizontal Multistage Pump



Vertical In Line
Multistage Pump



RPZ – API 610



RPAH– Slurry Pump



Megaflo
Horizontal Split case



Self-Priming



RPAP - Submersible
Aerator



RPSP- Sewage Submersible
Pump



Engine Drive Fire Pumps



Trailer Pump Engine Driven

Regent Pumps – Wide Ranging Applications



- Agricultural Irrigation
- Water treatment / RO System
- Mining
- Oil & Gas
- Power Station
- Marine Fire Fighting to FiFi I, II & III
- Palm Oil
- Chemical Plants
- Commercial / Industrial Buildings / Factory
- Leisure Park / Fountains
- Site Drainage
- Public Utilities Pumping Stations
- Sewage Plants
- Food Industries
- Marine – sea water pumps

✓ Quality

✓ Quick Delivery

✓ Reliability

✓ Customer Specific Need

Available From

Regent Asia Pacific Pty. Ltd. Australia
Projects and International Sales Division

Tel: +61 (0) 3 97726742 Mob: +61 430 827 300

email: sales@regentap.com.au <http://regentap.com.au>